

Chapter 3: Reflection from Spherical Mirrors

There are 2 types of mirrors; concave mirrors (caves in to the centre) and convex mirrors (bulges out at the centre)

Terms

- **Pole** = centre of the spherical mirror
- **Centre of curvature** = centre of the sphere where the mirror is made
- **Principal axis** = straight line through centre of curvature to pole
- **Focal point** = point halfway between the centre of curvature and pole
- **Focal length** = distance between focal point and pole

To draw an image on a spherical mirror we follow some simple rules. However we must remember that the laws of reflection still stand for spherical mirrors to. ($i = r$)

Reflection in a Concave Mirror

Rule 1: A ray which passes parallel to the principal axis, reflects through the focal point.

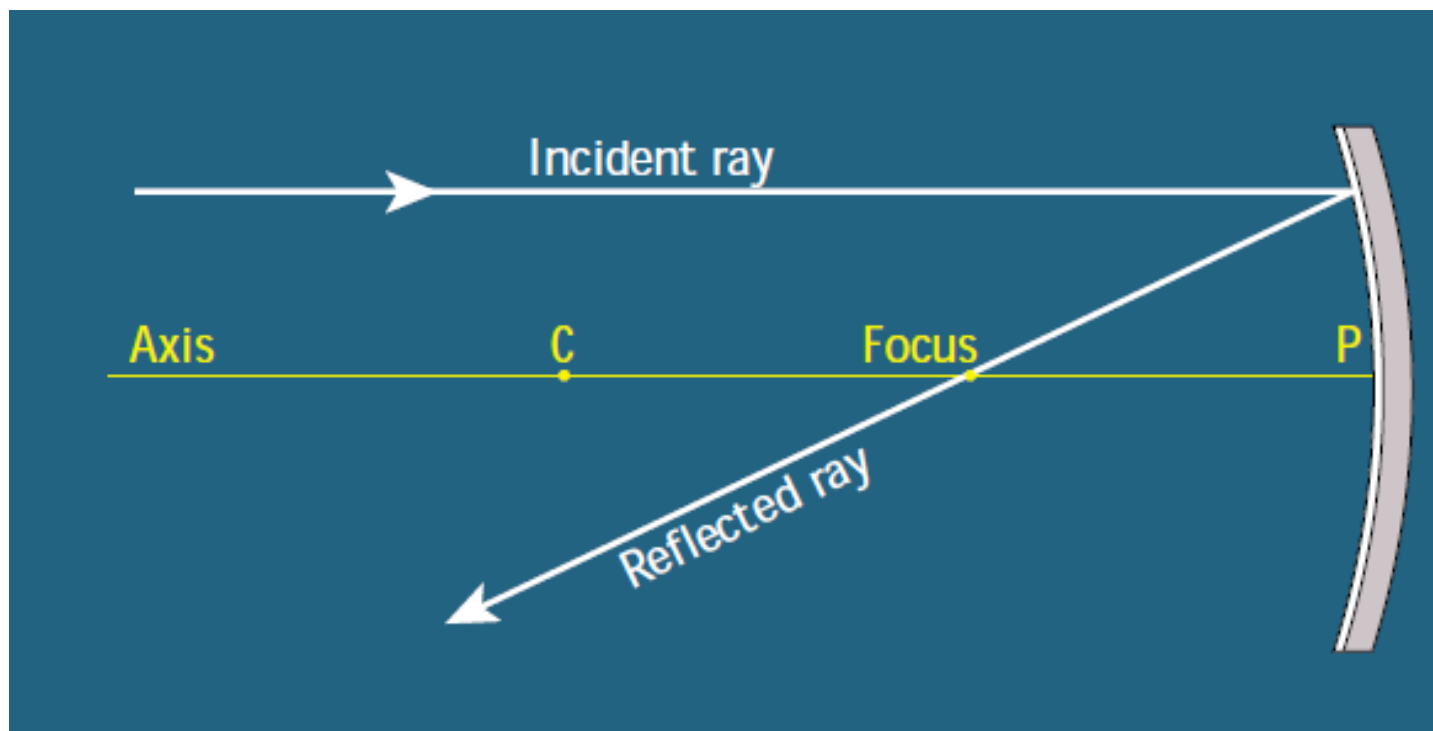

Rule 2: A ray which passes through the focal point, reflects parallel to the principal axis.

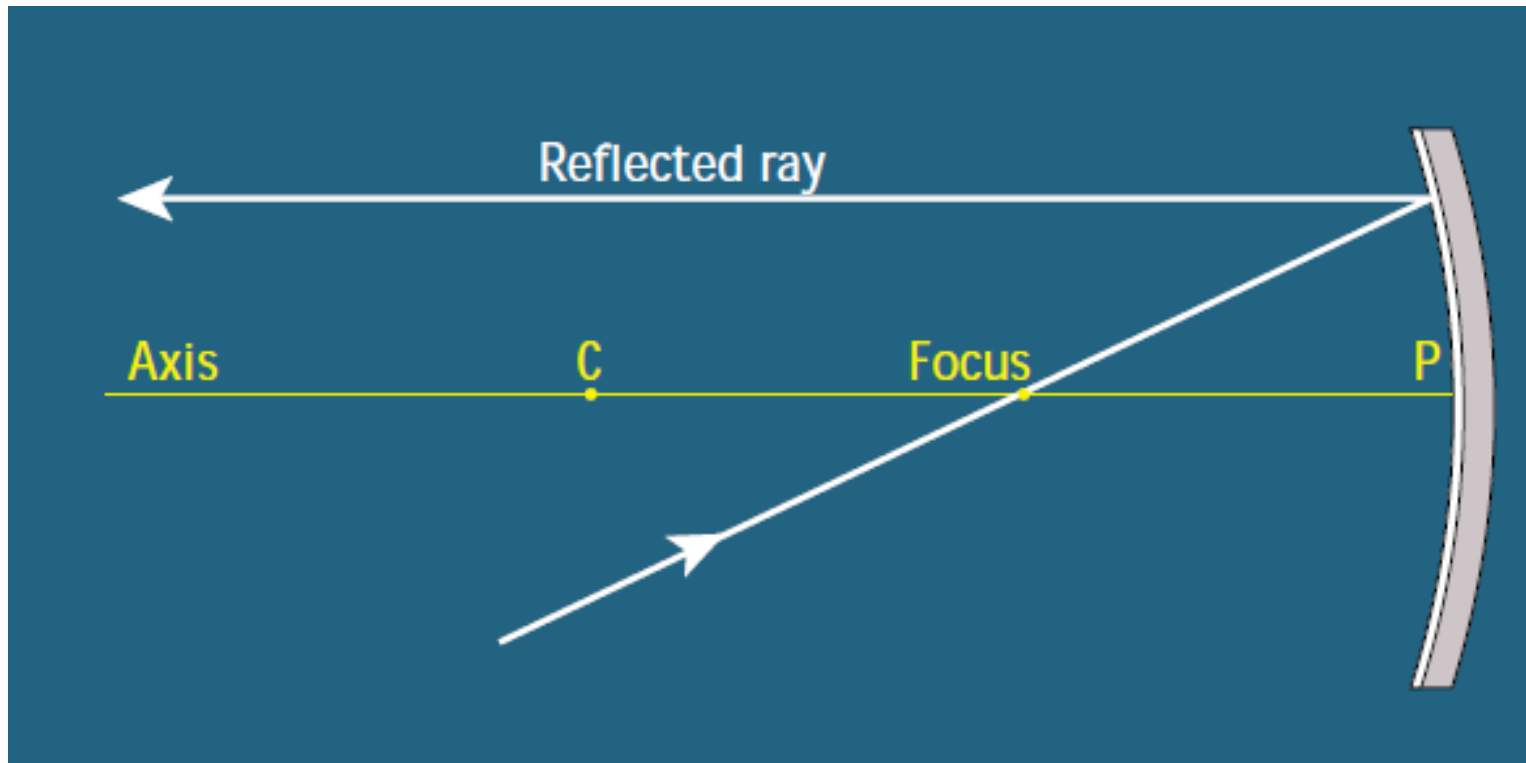

Rule 3: A ray passing through the centre of curvature gets reflected back through its own path.

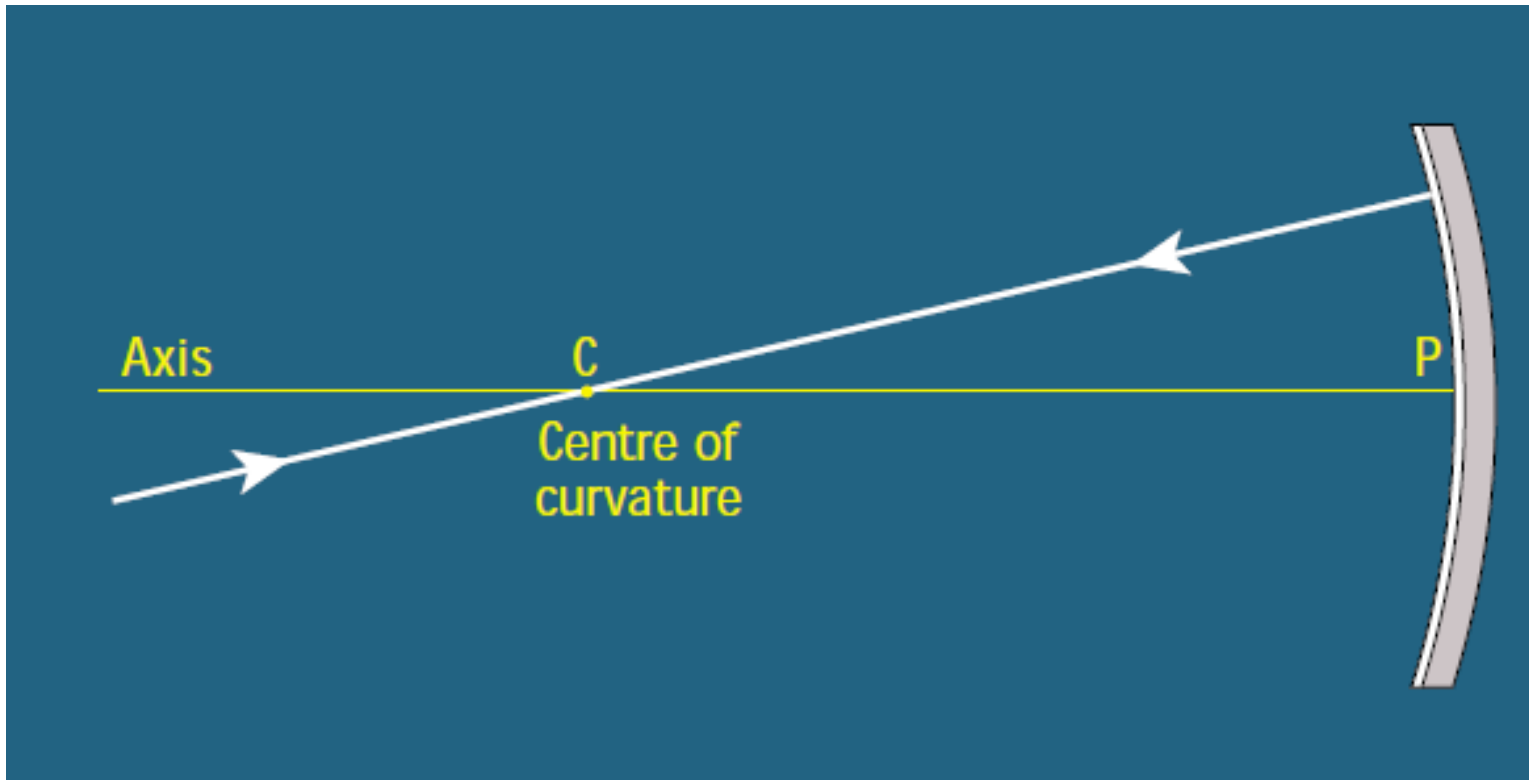

Rule 4: A ray which strikes the pole, gets reflected at an equal angle with the axis ($i = r$)

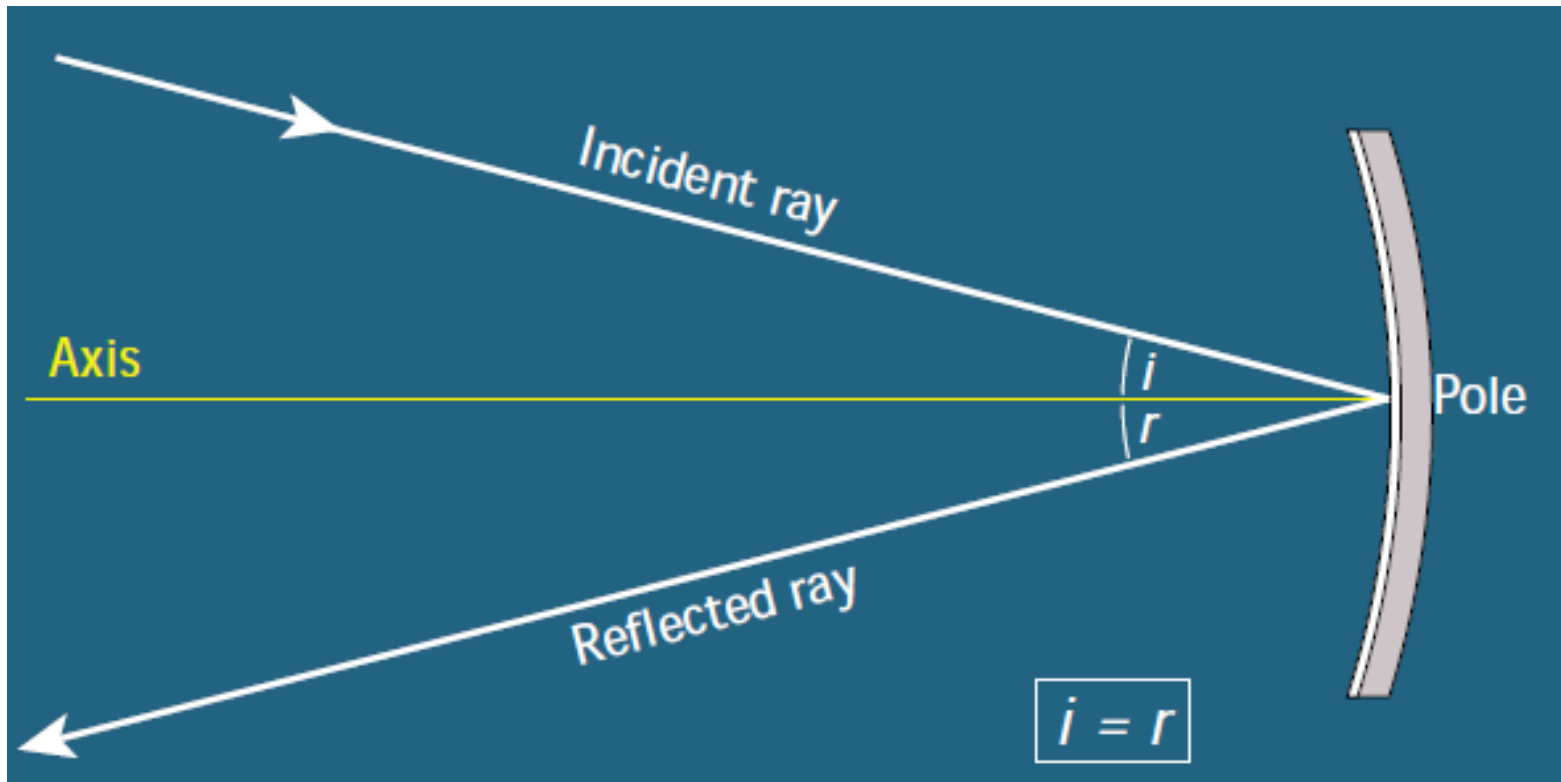

How an Image is Formed in a Concave Mirror.

Objects give out light in all direction. In the diagram, 3 rays have been drawn from the top of the object, following the rules we've just seen. All the reflected rays pass through the same point, X. If we repeated this for other points of the object, they'd all intersect at some point on the image. This image could be seen on a screen.

Fig. 3.9 page 16

However, we don't need all these rays. We only need 2!!

Remember a real image is the actual intersection of light rays.

The image on a cinema screen is a real image. (like fig 3.10)

For a Concave Mirror

If the object is outside the focus the image is real and located in front of the mirror

If the object is inside or at the focus the image is virtual and is located behind the mirror.

Object outside the centre of curvature.

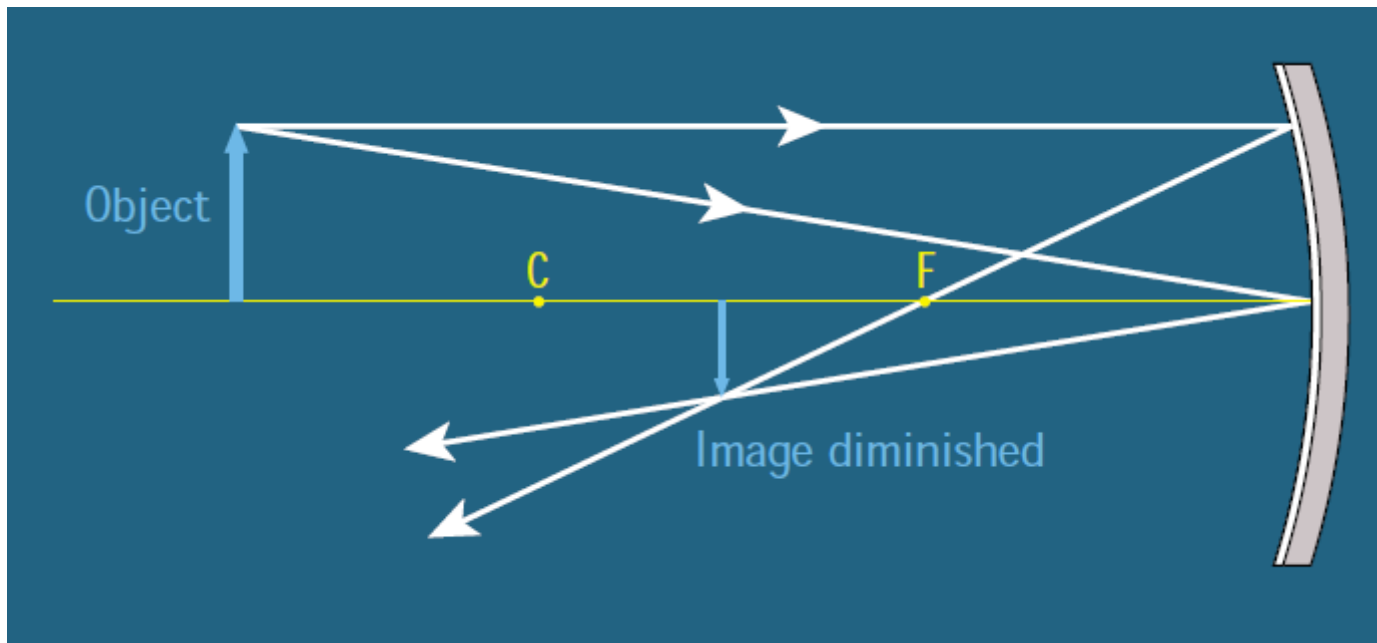

Object on the centre of curvature.

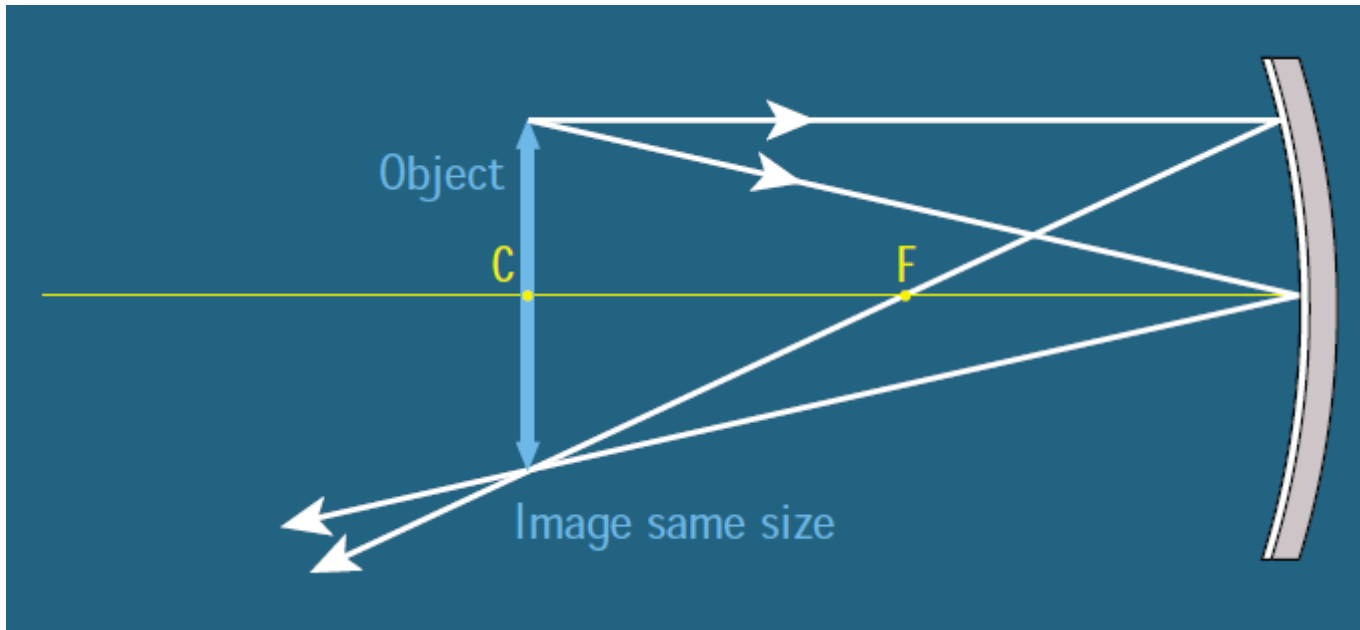

Object between the centre of curvature and focal point.

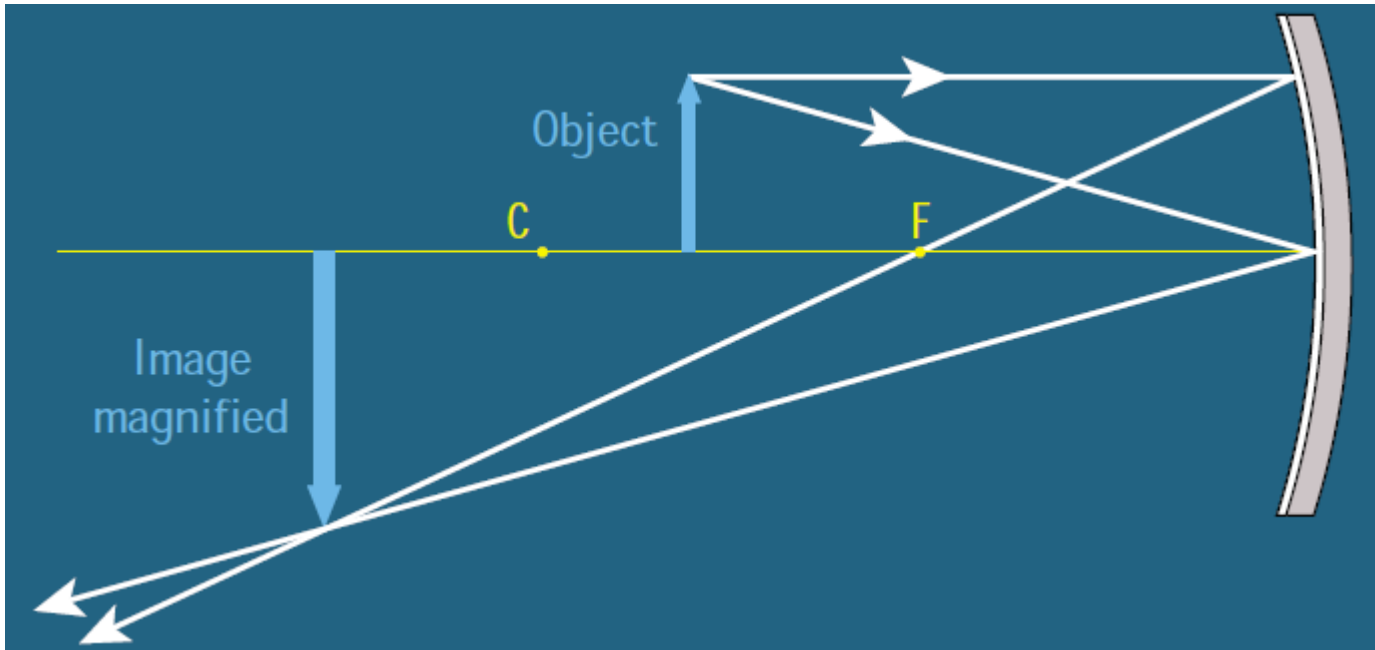

Object on the focal point.

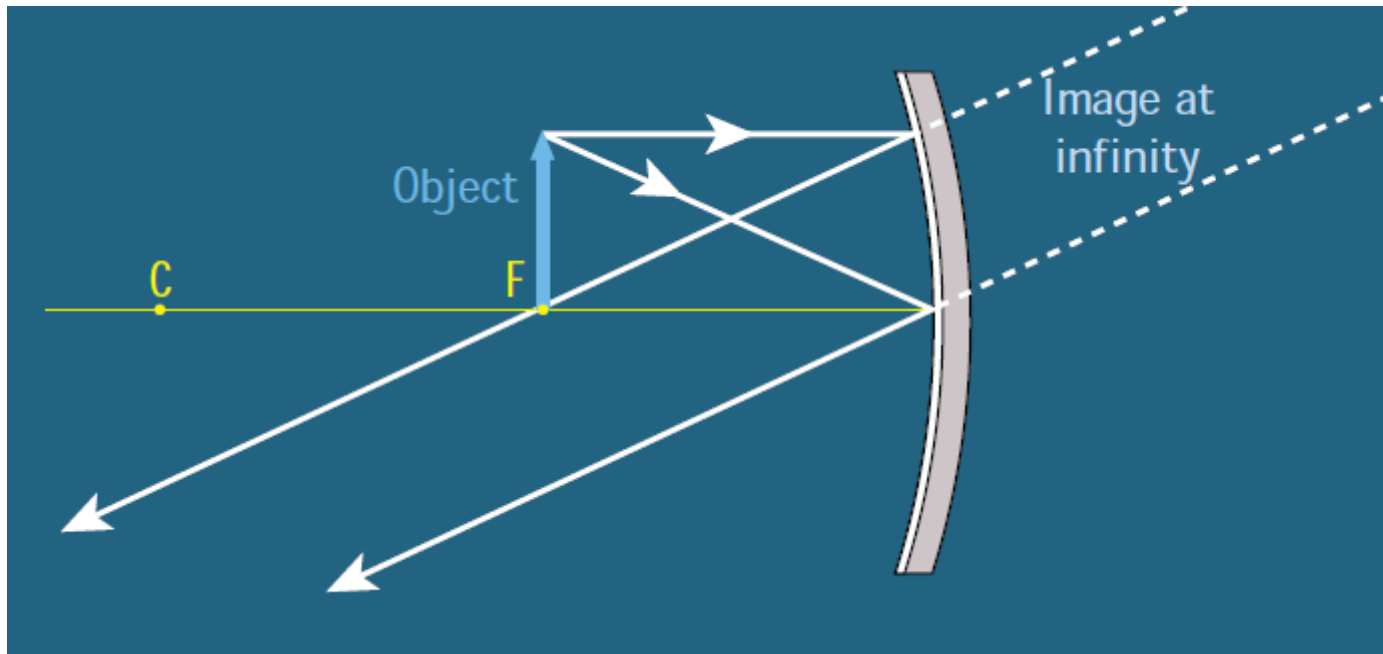

Object between the focal point and the pole.

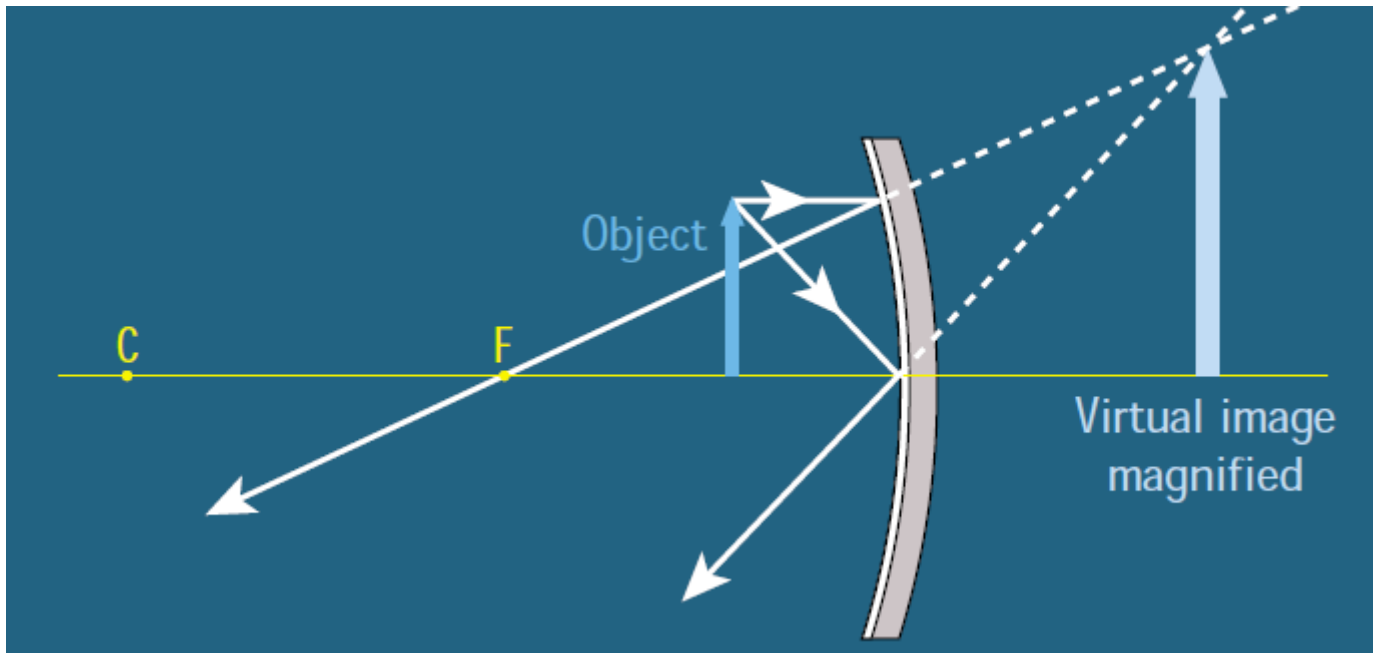

Formula for a Concave Mirror

u = distance from the object to the mirror

v = distance from the image to the mirror

f = the focal length

Formula for a real image $\frac{1}{u} + \frac{1}{v} = \frac{1}{f}$

Formula for a virtual image $\frac{1}{u} - \frac{1}{v} = \frac{1}{f}$

Magnification

The ratio of the height of the image to the height of the object is called the magnification. This is given by the formula

$$m = \frac{v}{u}$$

Example 3.1

An object is placed 15 cm in front of a concave mirror of focal length 10 cm. Find the position, magnification and nature of the image.

Example 3.2

An object is placed 40 cm in front of a concave mirror of focal length 15 cm. Find the position, magnification and nature of the image.

Example 3.3

An object 3 cm high is placed 20 cm in front of a concave mirror of focal length 25 cm.

- i. What is the distance of the image from the mirror?
- ii. What is the nature of the image?
- iii. What is the height of the image?

Example 3.4

The height of an image is 3 times that of the object when placed in front of a concave mirror of focal length 15 cm. What are the two possible locations of the object?

Example 3.5

The height of an image is 4 times that of the object when placed in front of a concave mirror of focal length 24 cm. What are the two possible locations of the object?

Reflection of light from a Convex Mirror

Similar rules apply here as in the concave mirror.

Same as rule 1

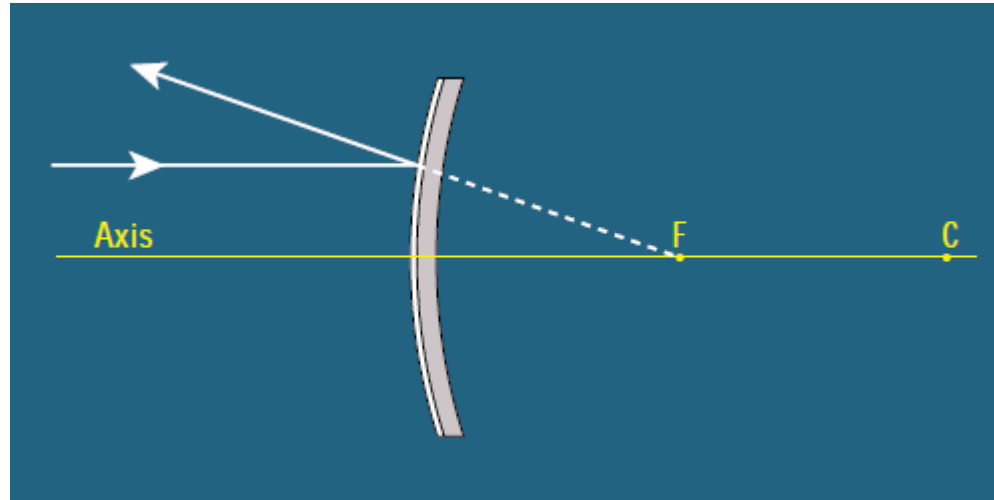

Same as rule 2

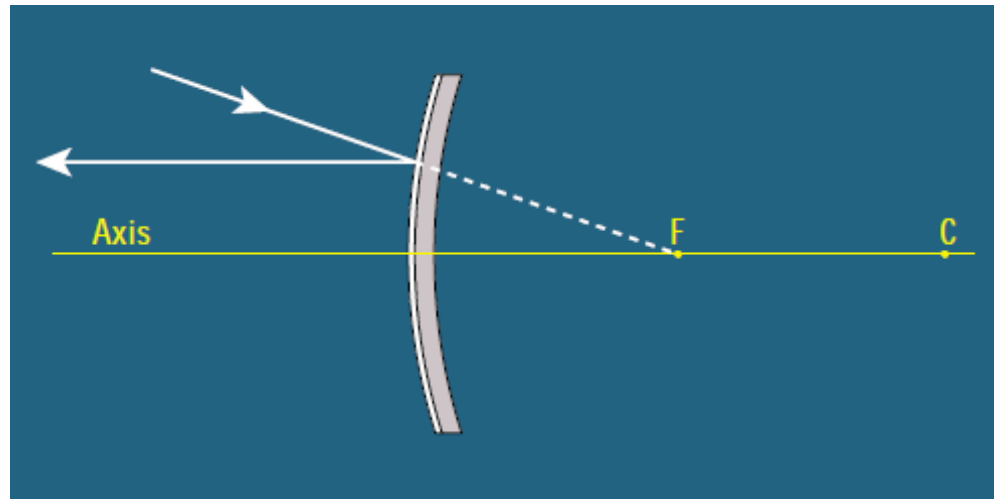

Same as rule 3

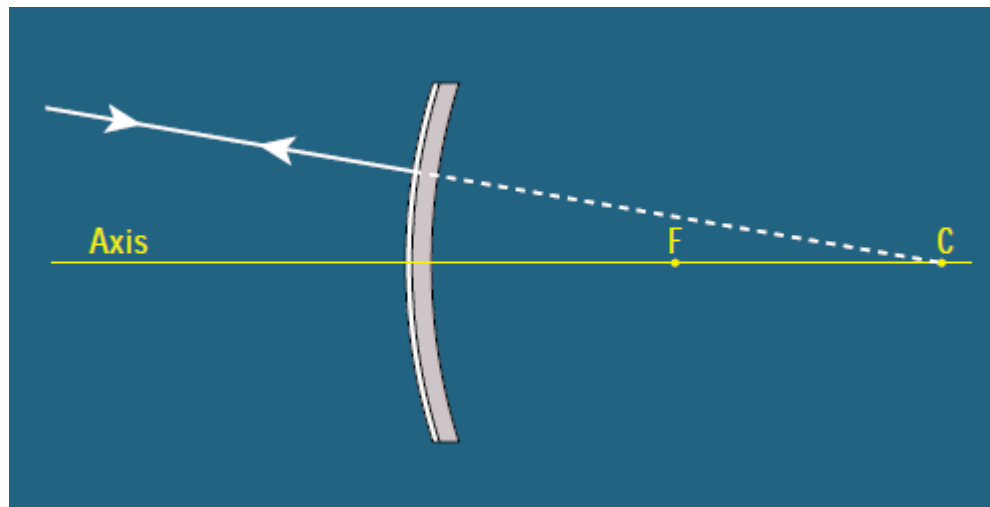

Same as rule 4

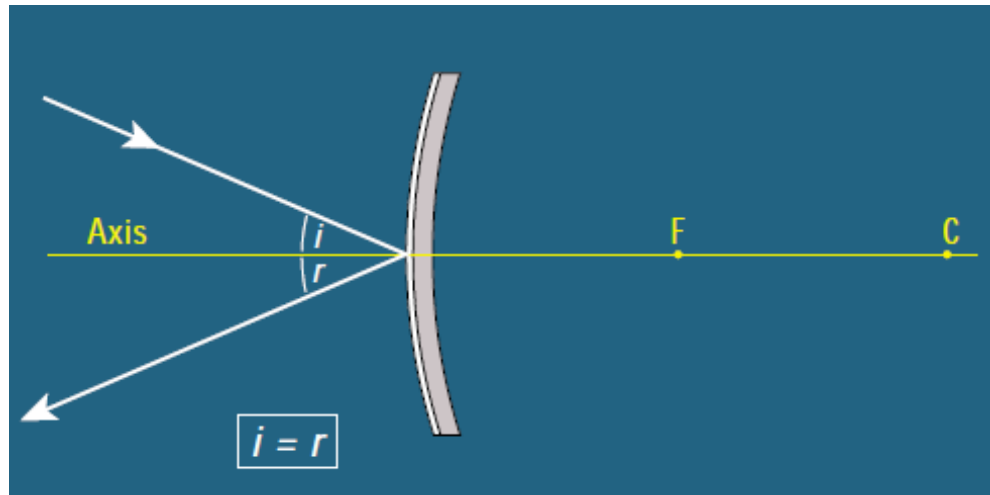

For a convex mirror, the image is always virtual and located behind the mirror. It is always diminished and the nearer you go to the mirror, the larger it gets.

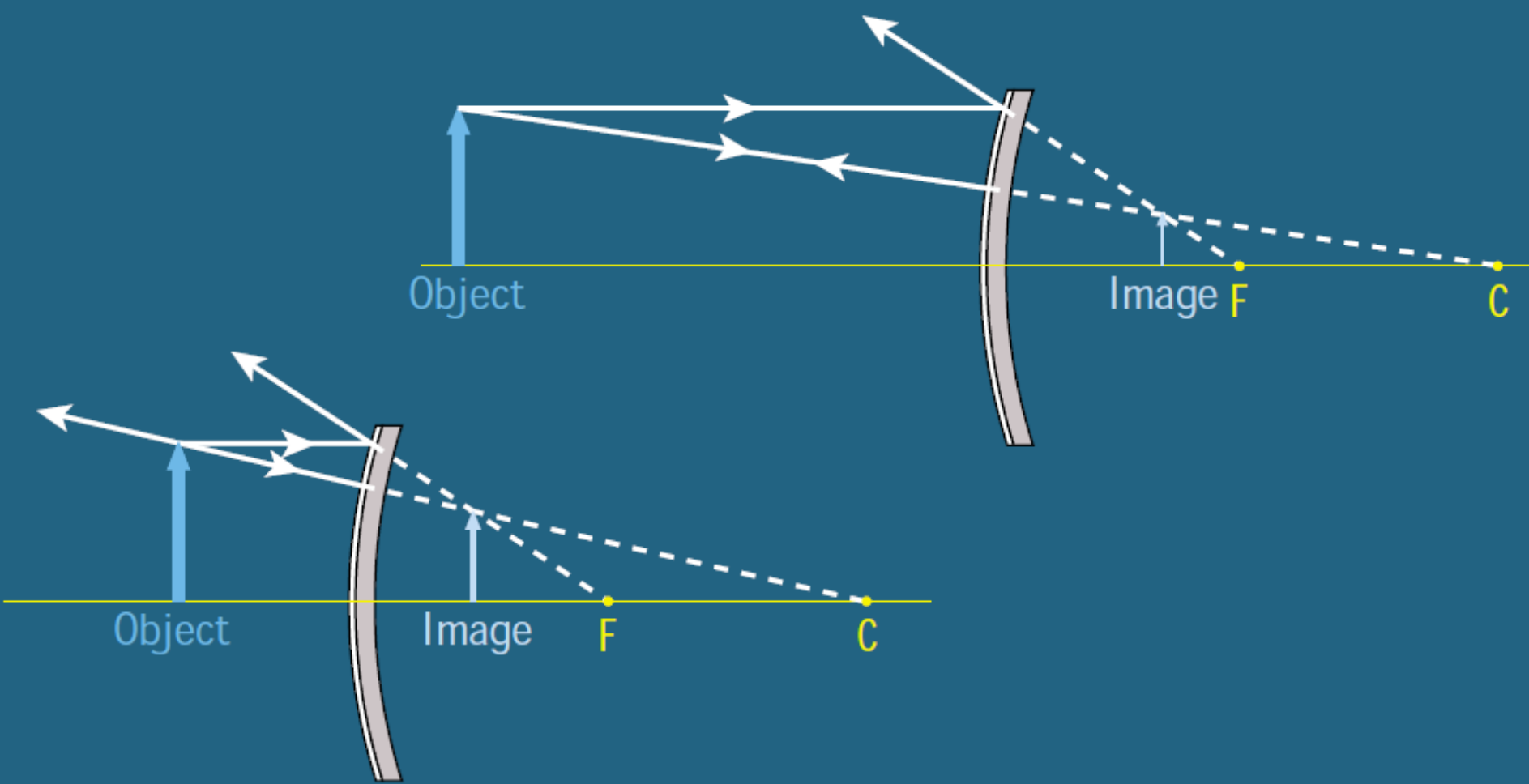

Problem:

A convex mirror has a centre of curvature of 6 cm. An object of height 3 cm is placed 8 cm in front of the mirror, find the height of the image.

Formula for a Convex mirror.

Formula: $\frac{1}{u} - \frac{1}{v} = -\frac{1}{f}$

Magnification: $m = \frac{v}{u}$

Example 3.6

An object 4 cm high is placed 30 cm in front of a convex mirror of focal length 20 cm.

- i. What is the distance of the image from the mirror?
- ii. What is the nature of the image?
- iii. What is the height of the image?

Example 3.7

A convex mirror of focal length 20 cm forms an image that is one quarter the size of the object. Find the positions of the object and image.

Uses of Mirrors (STS)

Concave	Convex
1. In car headlights and in flashlights.	1. Door mirror of a car
2. Shaving and make-up mirrors	2. At concealed entrances to give a view of oncoming traffic.
3. Dentists mirror	3. In shops for the shopkeeper to see hidden areas.
If a bulb is put in the focal point of a concave mirror, all the light would reflect back out parallel to the principal axis. This makes it effective.	